



# Oregon (Douglas Fir) in the Elements



Oregon, is the common trading name for Douglas Fir, a species of timber regularly imported from the west coast of North America which has been used extensively in residential and commercial construction in Australia for more than one hundred years.

Until 1992 there were no restrictions on external applications and Oregon has always had a high reputation as a structural timber with a very good service life when suitable installation and maintenance practices were followed.

This information bulletin is intended to describe where Oregon can still be used in many external applications including aspects of residential construction. The major factors to be considered are durability and the requirements of the Building Code of Australia as well as regulation imposed by State and Local Government authorities.

The guidance for this bulletin is drawn from the Residential Timber Frame Construction Standard, AS1684 and provides an interpretation of the recommendations contained within this Standard and also includes information about other commonly built structures used around a house that are not intended to be controlled under this Standard which are commonly built with Oregon, such as pergolas and gazebos.

## Residential Timber Framed Construction

Generally all residential (domestic house) construction would be built in accordance with AS1684. This standard makes the following requirement:-

Clause 1.10 Durability; “**Structural timber** used in accordance with this Standard shall have the level of durability appropriate for the relevant climate and expected service life and conditions including exposure to insect attack or to moisture which causes decay.”

The Standard continues to say “that **Structural timber** members that are in ground contact or that are not protected from weather exposure and associated moisture ingress shall be durability Class 1 or 2 as appropriate or shall be treated with preservatives.”

For general guidance purposes the Standard recognises that there are four

areas of durability for structural timbers. It also recognises that there are exceptions to the rule. The following briefly describes these four areas and

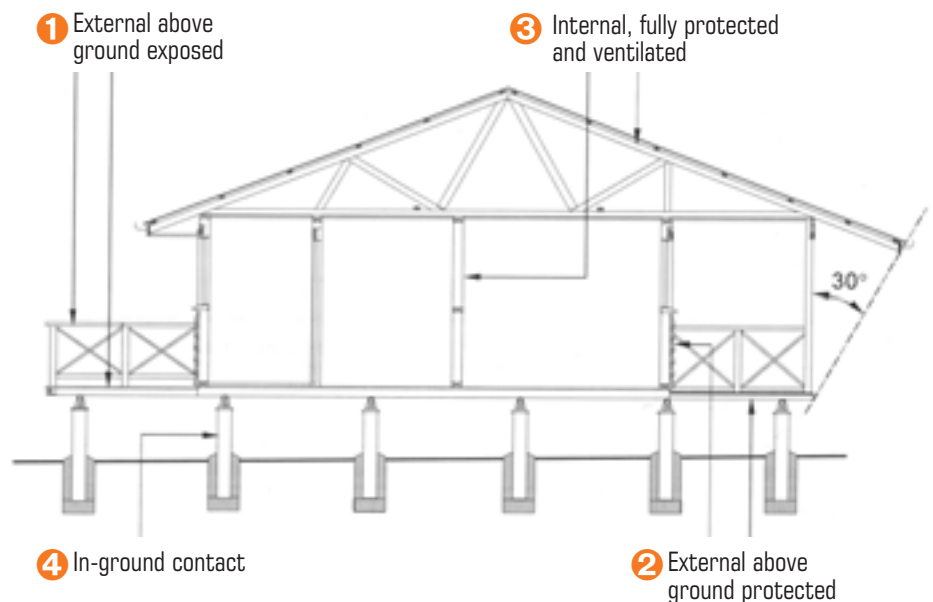

> Figure 1 – Application of Exposure Condition Ratings 1–4

comments on the consequence this has on the use of Oregon (Douglas Fir):-

### 1 External Above Ground Exposed

- Timber Durability Class 1 or 2 timbers with sapwood removed or preservative treated to H3;
- Low durability softwoods preservative treated to H3;
- Some durability Class 3 or 4 timbers are suitable in some locations.

**Comment:** Clause C1 recognises that there may be some situations where timbers of natural lower durability may be acceptable, for example, structures that are intended for short service life or partially exposed to the elements such as posts, that are well ventilated, protective coated, well maintained and do not collect water. Refer Figure 1 for definition of exposure.



This publication was produced by the Australian Timber Importers Federation, in conjunction with the Forest and Wood Product Research and Development Corporation. Australian Timber Importers Federation – A federation of timber importers associations, consisting of: NSW Timber Importers Association; Victoria Timber Importers Association; Queensland Timber Importers Association; South Australia Timber Importers Association

With the compliments of:



# Oregon (Douglas Fir) in the Elements

## 2 External Above Ground Protected

- Timber Durability Class – 1, 2, 3 or 4 timbers.

External timbers are regarded as protected if they are covered by a roof or roof projection, refer to Figure 1. The Standard regards protection being achieved if the roof projections or similar are at 30° to the vertical. It must also be well detailed and maintained (painted or stained) and kept well ventilated.

**Comment:** Oregon (Douglas Fir) is a durability class 4 timber. No restrictions apply for this species provided that a roof structure as defined in the Standard gives the adequate level of protection.

**Posts Partially Protected by Roof Projection:** Oregon (Douglas Fir) may be used as a post that has the majority of the element protected by a roof if the timber is well maintained and is in a vertical orientation. This is allowable because it is well understood that vertical building elements have a longer service life than horizontal elements. Vertical elements do not collect, and hold less water or moisture which can cause decay. These posts must be well ventilated, have a protective coating applied and have ready access for maintenance.

## 3 Internal, Fully Protected and Ventilated

- Timber Durability Class 1, 2, 3 or 4 timbers

**Comment:** This allows the use of Oregon (Douglas Fir).

**NOTE:** Framing in extremely damp or unventilated locations should have the durability required for external above-ground situations.

## 4 In-ground Contact

- Timber Durability Class 1 or 2 timbers with sapwood removed or preservative treated.
- Low durability softwoods preservative treated.

**Comment:** Oregon (Douglas Fir) should not be used for this application.

## Other Timber Framed Domestic Building Applications

Many other building applications exist around a house that are, by their non-critical nature, considered non-structural and therefore do not need to comply with the requirements of AS1684.

Applications such as free standing carports, pergolas and gazebos, or building elements like barge or fascia boards are not considered **structural** and therefore Oregon (Douglas Fir) or any timber of any species can be used.

For instance pergolas that are attached to the wall of the house by a ledger are not considered to be a part of the house and are therefore **non-structural**.

These other application are also not expected to have the same service life as house frames as they are normally readily accessible and more easily maintained.

Whilst compliance with the Standard is not necessary it can be used as a guideline for design, building practice and procedures as well as determination of member sizes through the extensive range of span tables and for bracing and connection details.

In AS1684 Section 1.1 Scope, it recognizes that there are other

applications which can have a less conservative level of design and may even be permitted by building regulations and other Australian Standards.

AS1684 has no requirements for timbers that are **non-structural**. Only general guidance is offered, referring users to Appendix C – Durability.

Appendix C – Clause C1 Durability States:- “Timber used for house construction should have the level of durability appropriate for the relevant climate and expected service life and conditions; that is exposure to insect attack or to moisture which will cause decay.

In some situations, the climatic conditions (colder, drier, etc.) or the lower risk of insect attack or the careful detailing of joints and application and maintenance of protective coatings may be such that a lower durability to that listed could be used”.

## Improving Service Life of a Timber Structure

The service performance of any timber component in weather exposed situations or a high moisture environment depends on protecting it from absorption of moisture. The preferred detailing suggested in this leaflet is aimed at reducing the ingress of water into the timber component by providing non-permeable surfaces and details that do not trap water.

Figures 2 and 3 opposite offer guidance on building practices that will enhance the service life of all timbers in exposed applications.



## > Suitable Applications for Oregon

### ① Pergolas

Provided it is not a continuation of a roof structure.

- Posts
- Beams
- Purlins
- Battens

### ② Verandah Posts

Suitable for single storey where the post is supported clear of the ground.

### ③ Fascia and Barge Boards

Prime coat all round before fixing.

### ④ Fences

Posts and rails should be Durability Class 1 or 2 or suitably treated.

- Palings
- Sloped Capping

### ⑤ Lattice Panels and Frames

Used as screens around pergolas, decks or verandahs but not as safety fences.

### ⑥ Cladding

When protected by an overhang that is 30° to the vertical as shown at ② in Figure 1.

**NOTE:** A pergola or patio roof that shares members with the house roof frame is regarded as a part of the house and therefore considered to be **structural** and must comply with AS1684 requirements.

 = Where brush on preservatives should be applied to all joints and end grain

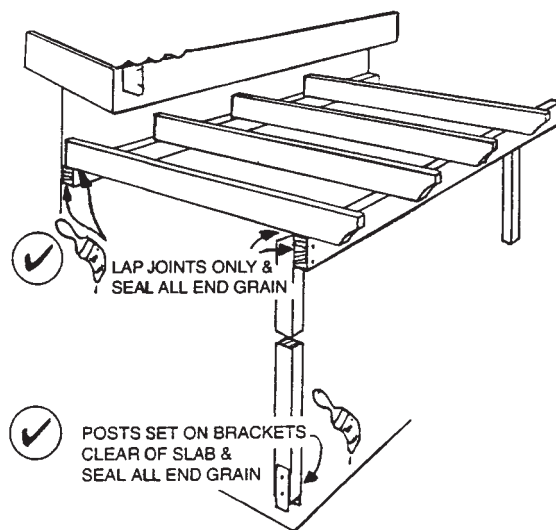
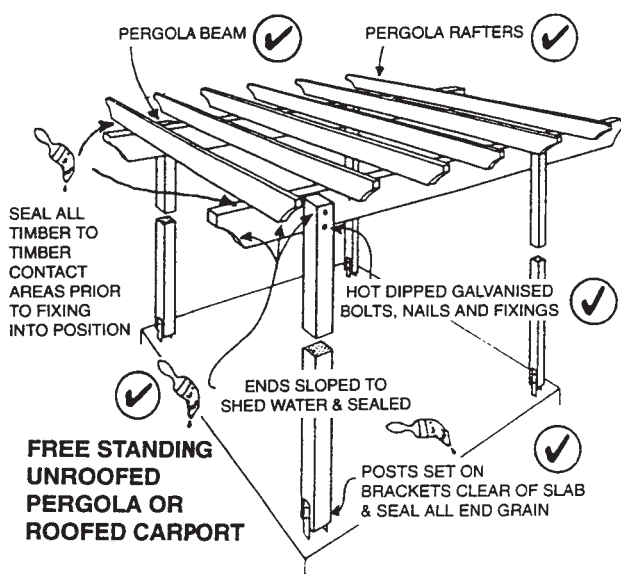

Figure 2 – Pergola connected to ledger or fascia (roofed or unroofed)



> Figure 3 – Free Standing Applications

### PATIO ROOF AND SUPPORT POST

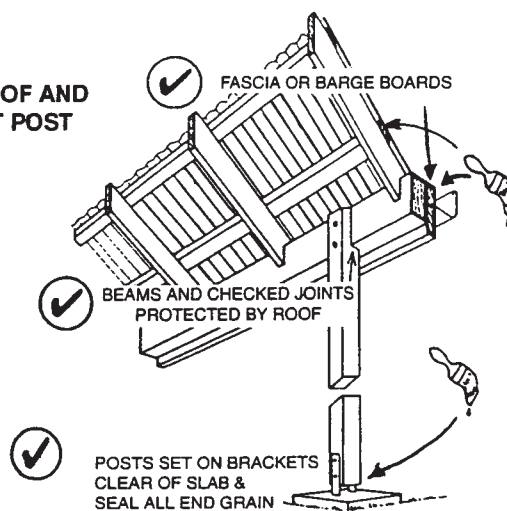

Figure 4 – Allowable connected applications



# Oregon (Douglas Fir) in the Elements

## Building Practices Recommendations for the Use of Oregon in Weather Exposed Applications

As outlined previously Oregon can be used in many external applications, those as part of a house structure as allowed under the requirements of AS1684 and those that are non-structural and therefore have no formal regulation.

Regardless of these requirements good building practice for all timber species including Oregon should always be followed :-

### > Timber Specification

- Always use timber that is free of heart centre (FOHC) that is free of corewood, material which comes from within the centre 50mm of the tree.
- Timber should be free of sapwood, lighter coloured wood from the outer layers of the tree.
- All timber should be free of splits, checks, loose knots, holes and other cavities.

### > Installation

- All timber to timber joints should have a preservative coating prior to installation.
- Preservative coatings should be applied inside all bolt and service holes.
- All end grain should be preservative coated.

- Housed, checked or birdsmouth joints that can trap water should be avoided where possible.
- Use corrosion resistant fasteners, ie hot dipped galvanised, stainless steel or composite bolts, nails and or nail plate connectors.

### > Finishing

Refer to manufacturers' specification regarding method of application, number of coats and maintenance.

Suggested finishes are

- Pigmented oil based stains.
- Pigmented paint over an oil based primer.

A wax free preservative pre-treatment is recommended for both finish systems.

**NOTE:** Unpigmented finishes including clear film finishes have limited life when exposed to UV-light (sunlight) and should be avoided, as excessive maintenance may be required.

### > Maintenance

- Inspect the structure at least annually, or more often as desired, to check that finishes have not weathered in high exposure situations and for signs of possible insect attack.
- Repair weathered finishes.
- Eradicate insects if detected, repair or replace any affected timber.
- Re-apply finishes in accordance with manufacturers specification, before finish breakdown occurs.

**Oregon (Douglas Fir)** is one of the most popular timbers imported into Australia, regularly available in a wide range of sizes and lengths for many different applications. For more information on Oregon it is recommended that you obtain a copy of the Australian Timber Importers Federation, Timber Users Guide 3.1 Douglas Fir.

### Further Reading

This is one brochure in a series of Imported Timber Information Bulletins numbered 1 to 5, the complete series is available from your local Timber Advisory Service or by downloading from the Technical Bulletin section of [www.timber.net.au](http://www.timber.net.au)

- Wood in Australia – Keith R Bootle published by McGraw-Hill Book Company.
- Selecting Timber – a publication of BRANZ.

For further information on this brochure, contact the Timber Advisory Service on free call 1800 044 529 or email [showroom@tdansw.asn.au](mailto:showroom@tdansw.asn.au) Level 6, 525 Elizabeth Street, Surry Hills NSW 2010. General Information on the use of timber can also be found at the web page [www.timber.net.au](http://www.timber.net.au)

**Important notice:** The information and advice provided in the publication is intended as a guide only. As successful design and construction depends upon numerous factors outside the scope of this publication, the Forest and Wood Product Research Corporation accepts no responsibility for specifications in, nor work done or omitted to be done in reliance on this information sheet. Whilst all care has been taken to ensure the accuracy of the information contained in this publication, the Forest and Wood Product Research Corporation disclaims, to the full extent permitted by law, all and any liability for any damage or loss, whether direct, indirect, special or consequential, arising directly or indirectly out of use of or reliance on this guide, whether as a result of the Forest and Wood Product Research Corporation negligence or otherwise.

FOREST  
&  
WOOD  
PRODUCTS  
Research & Development Corporation

FWPRDC is jointly funded by the Commonwealth government and the Australian forest and wood products industry